

LOGISTICS SOLUTIONS GUIDE

Logistics automation solutions for retail distribution, e-commerce, and parcel processing organizations

THE GLOBAL LEADER

IN MACHINE VISION AND INDUSTRIAL BARCODE READING

Cognex®, the leading supplier of machine vision and industrial barcode reading solutions.

With over 3.5 million systems installed in facilities around the world and over 41 years of experience, Cognex is focused on industrial machine vision and image-based barcode reading technology. Deployed by the world's top manufacturers, suppliers, and machine builders, Cognex products ensure that manufactured items meet the stringent quality requirements of each industry.

Cognex solutions help customers improve manufacturing quality and performance by eliminating defects, verifying assembly, and tracking information at every stage of the production process. Smarter automation using Cognex vision and barcode reading systems means fewer production errors, which equates to lower manufacturing costs and higher customer satisfaction. With the widest range of solutions and largest network of global vision experts, Cognex is the best choice to help you **Build Your Vision.™**

**\$1.04
BILLION**
2021 REVENUE

OVER 41
YEARS IN THE BUSINESS

500+
CHANNEL PARTNERS

GLOBAL OFFICES IN
20+ COUNTRIES

3,500,000+
SYSTEMS SHIPPED



LOGISTICS SOLUTIONS

POWER UP YOUR OPERATIONS WITH IMAGE-BASED BARCODE READERS AND VISION SYSTEMS

As retail distribution, e-commerce fulfillment, and parcel processing industries continue to grow, the pressure to meet customer demands and performance metrics is greater than ever. Successful companies are scaling and optimizing operations while minimizing manual work and equipment downtime. Cognex machine vision and barcode reading solutions deliver high accuracy and robust performance which helps improve traceability, increase throughput, and reduce costs associated with manual rework. In addition, these solutions provide rich real-time performance data and trending insights that help optimize operations.

| | |
|--------------------------|---|
| Inbound Logistics | 4 |
| Order Fulfillment | 5 |
| Sortation | 6 |
| Outbound Logistics | 7 |

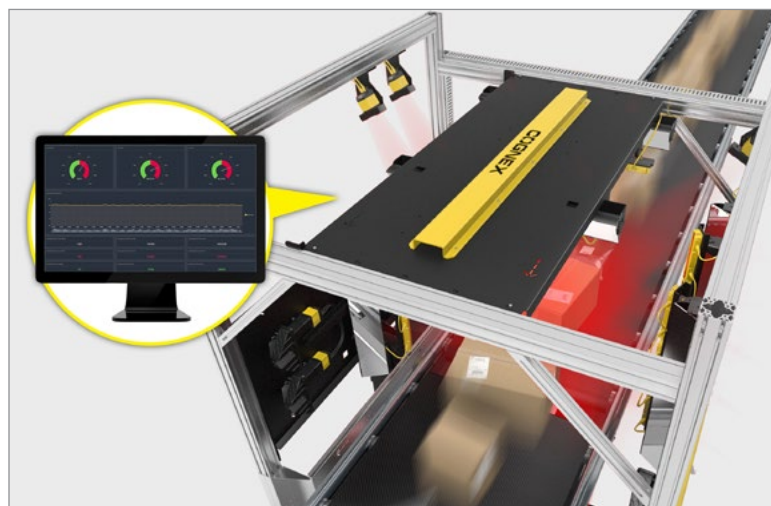
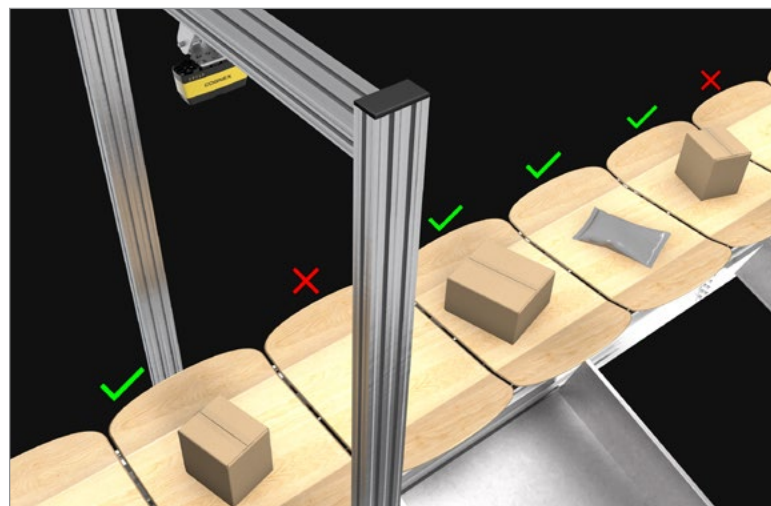

INBOUND/RECEIVING

No matter the size of your operation, the logistics process begins with receiving inbound goods. With demand growing, maintaining efficiency and throughput is more important than ever. Using high performance and reliable image-based barcode readers and machine vision systems, organizations receive incoming product faster and track product more effectively as it moves through the facility.

Inbound Product Categorization

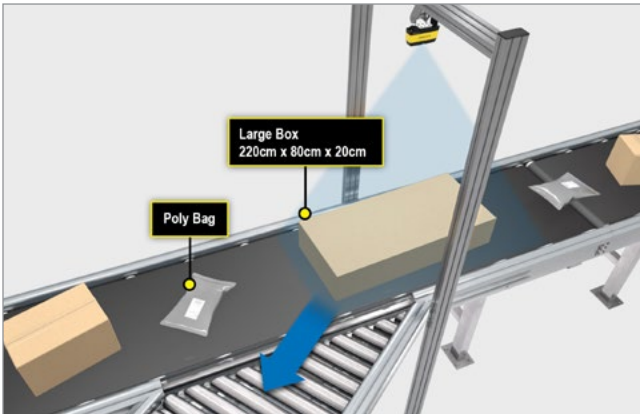

The 3D-A1000 Dimensioning System captures dimensional information and categorizes incoming freight preventing handling damage downstream and provides item data for proper storage.

Manifest Verification

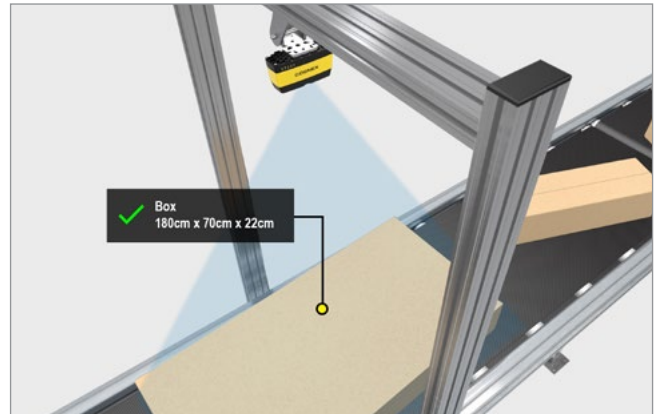

The 3D-A1000 Dimensioning System captures volumetric and dimensional information of incoming product improving traceability, verifying what was on the manifest, accurately tracking inventory.

Pallet Scanning



With a large depth-of-field and wide field-of-view, Cognex pallet scanning systems read incoming pallet identification labels quickly and accurately, even when surrounded by other labels and plastic shrink wrap.

Print and Apply During Inbound Processing

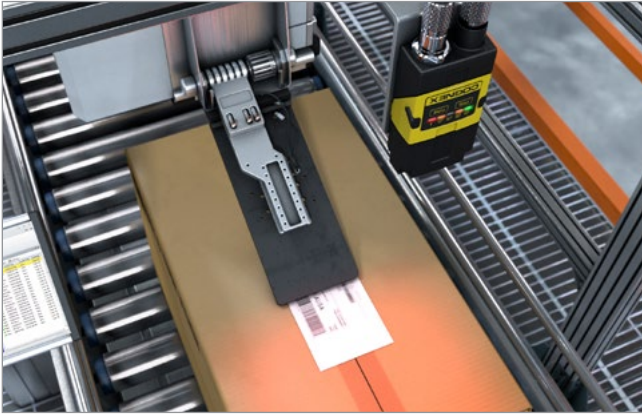

Cognex image-based barcode readers use code quality metrics and grading to identify and reject poorly printed codes attached during the inbound process, allowing facility managers to identify and fix printer errors to minimize problems downstream.

Automated Inbound Receiving



Overhead presentation reading stations or multi-reader barcode scan tunnels decipher codes on various sides of a package, at extreme angles, and different orientations reducing rework and lowering costs.

ORDER FULFILLMENT

Consumer shopping behavior has shifted and blurred the lines between retail distribution and traditional e-commerce fulfillment platforms. This transition coupled with rising demand means more and more single item orders flow through the system with increasingly short delivery expectations. High performance image-based barcode readers and machine vision systems are increasingly playing a critical role in helping organizations meet increased order demand and increase the efficiency of the order fulfillment process, while improving order accuracy and delivering on customer promises.

2D Barcode Guidance for AGVs

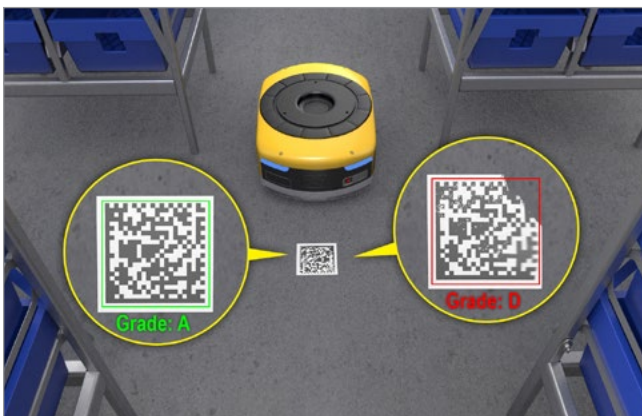

Barcode readers quickly and accurately read 2D codes on the floor, even if they are smudged or damaged, allowing automatic guided vehicles (AGVs) to navigate the warehouse to bring product to pick station operators. Print Quality Metrics grade codes and report when barcodes start to degrade so they can be fixed before there is a problem.

Packaging Optimization

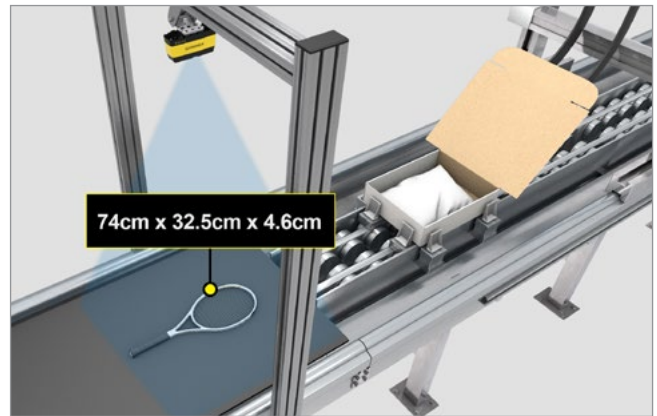

The 3D-A1000 Dimensioning System automates the volumetric measurement of picked products allowing operators to select the best packaging option, reducing manual handling and measurement time, increasing operator efficiency, and reducing shipping costs.

Pick and Pack



Cognex image-based barcode technology quickly reads omnidirectional, damaged, smudged, and distorted codes and codes at extreme angles, improving pick and pack sorting times and maximizing throughput.

Item Verification

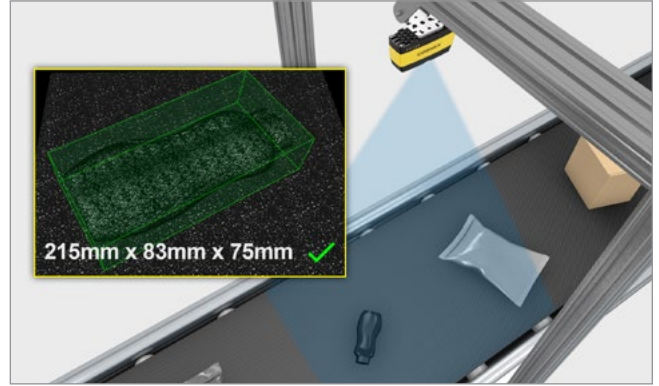

The 3D-A1000 Dimensioning System quickly and accurately captures volume and dimensioning data of picked items which increases order accuracy, improves inventory management, and lowers return costs.

Print and Apply with Verification



Image-based barcode readers catch label print and placement issues early on, allowing facility managers to identify and fix label or printer errors to minimize problems downstream.

Zone Routing



Image-based barcode readers, with advanced algorithms and decoding technology reliably read damaged, or non-aligned barcodes on totes in small egress situations to send them to the right pick station.

Tote-Fill Optimization

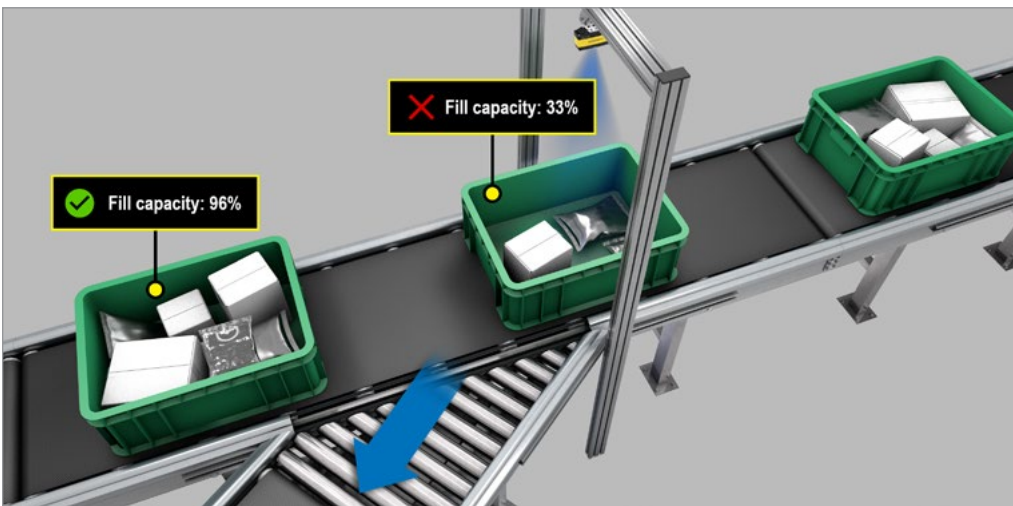

The 3D-A1000 dimensioning system, which features a 3D and 2D camera system, calculates tote capacity and fill heights and compares those values to established target values. The system can be configured to flag and alert over or underfilled totes and diverts them for correction, increasing order accuracy and reducing costly challenges due to lost or damaged products.

SORTATION

E-commerce fulfillment, retail distribution, and parcel processing facilities rely on their ship sorting system to rapidly sort outgoing product and parcels prior to shipment. As demand has increased, these organizations are under more pressure to ensure orders reach the right destination within the expected delivery timeframe. Highly accurate barcode readers and machine vision systems are playing a larger role in helping organizations improve sorting throughput, decrease product loss, and optimize their operations with process data.

Categorizing Packages Prior to Shipment

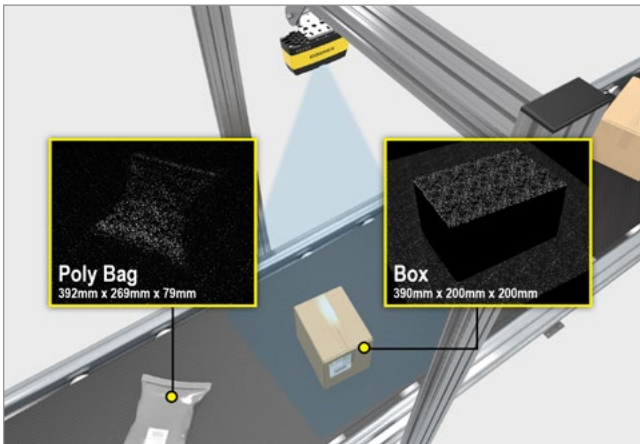

The 3D-A1000 Dimensioning System quickly and accurately categorizes products to ensure proper handling, which reduces damage to packages and keeps the sorter line moving smoothly.

Item Detection

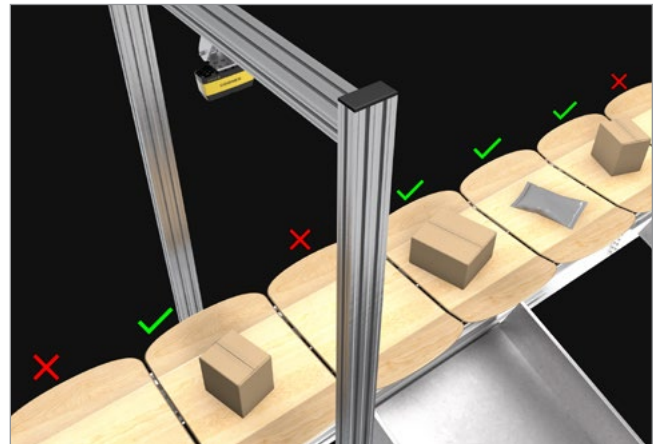

The 3D-A1000 Item Detect System use 3D and 2D data to correctly identify objects among dirt, dust, and foreign objects on the sorting belt, and provide information and any error codes to keep sorting systems running efficiently.

Ship Sorter Induction



Image-based barcode readers use advanced algorithms and decoding technology to quickly read codes on parcels and packages entering the sorting system, adding traceability and efficiency to the sorting process.

Ship Sorter Scanning

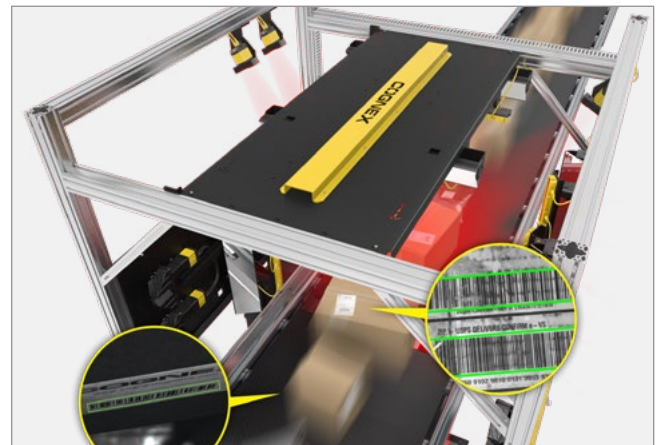

Cognex barcode scanning tunnels are designed to read damaged codes at extreme perspectives on all sides of the box, even with the high speed and small gapping requirements of today's ship sorters. This allows a facility to increase throughput, without impacting sort accuracy.

OUTBOUND LOGISTICS

Retail distribution, e-commerce fulfillment, and parcel processing facilities are under more pressure to deliver products to customers due to rising demand. Reliable and highly accurate machine vision systems and barcode readers are increasingly critical to help operations teams improve traceability, load their trucks more efficiently, and make sure outbound packages get to the correct place, on time and at optimal cost.

Estimating Shipping Costs

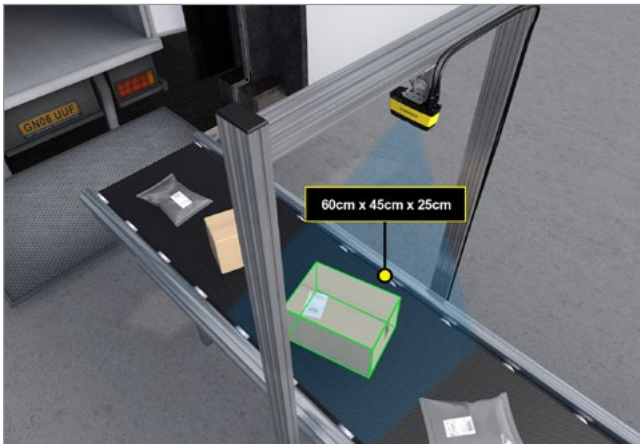

The 3D-A1000 Dimensioning System captures and reports dimensional and volumetric information allowing operators to select the optimal packaging and more accurately estimate shipping costs.

Outbound Scanning

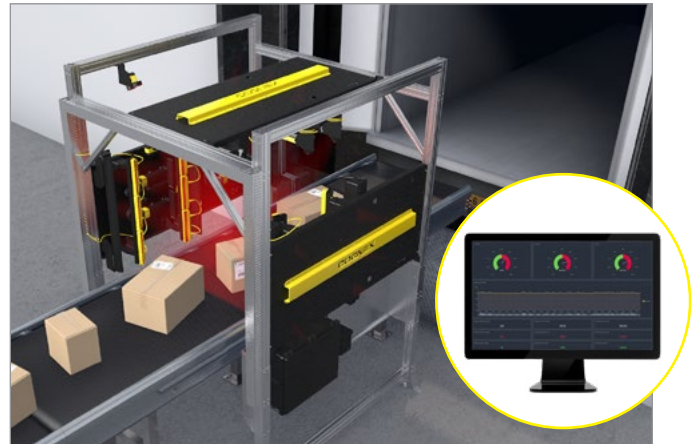

Barcode readers help distribution centers improve accuracy and traceability of outbound shipping processes by providing a hands-free, efficient solution to verifying the correct packages are loaded onto the truck.

Palletizing Outbound Shipments

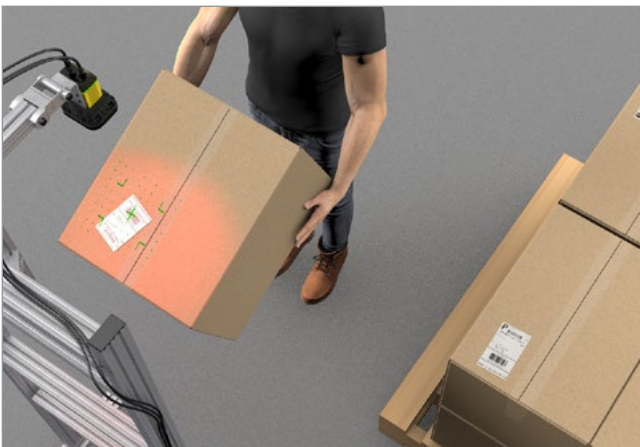

Deploying image-based barcode readers overhead helps facilities load outgoing trucks faster by enabling operators to build pallets more efficiently than using a hand scanner.

Truck Load Optimization

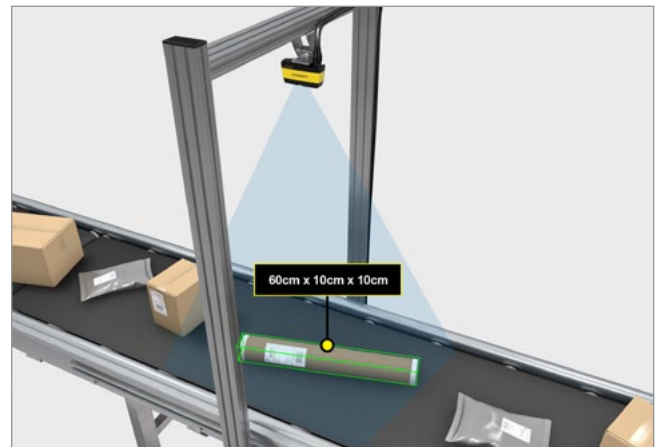

The easy-to-use 3D-A1000 Dimensioning System delivers dimensional and volumetric information for outgoing freight allowing outbound logistics operators to pack their trucks efficiently to optimize transportation costs.

TECHNOLOGY

FOR OPTIMAL PERFORMANCE AND TRACEABILITY

1DMax with Hotbars Technology

1DMax® with Hotbars® is optimized for omnidirectional 1D barcode reading, decoding up to 10x the speed of a conventional barcode reader, even with increased noise, limited contrast, and damage.



2DMax with PowerGrid

2DMax® with PowerGrid® is a breakthrough 2D decoding algorithm and technology designed to read 2D codes with significant damage to or complete elimination of a code's finder pattern, clocking pattern, or quiet zone.

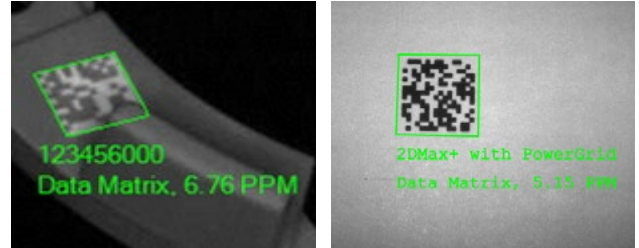

OCRMax

OCRMax™, a font-trainable optical character recognition and verification (OCR and OCV) tool, has set industry records for ease of use, read rates and speed in complex images. This powerful algorithm prevents misreads, handles process variations, and provides easy font management.

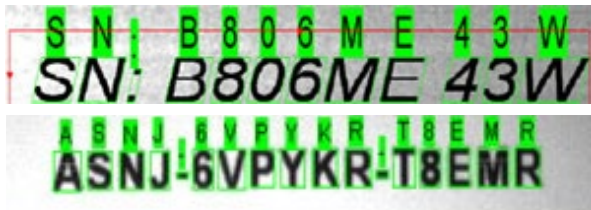

Symbolic Light Technology

Unlike conventional methods, the 3D-A1000 uses patented 3D symbolic light technology to freeze motion with a single image. This generates more accurate 3D point cloud data, eliminating the need for complex calibration and encoder integration.

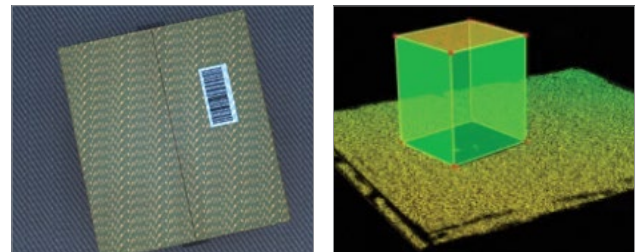

3D symbolic light

3D point cloud

Edge Intelligence

Cognex Edge Intelligence (EI) technology transforms big data into smart data to improve overall equipment effectiveness (OEE) and throughput. EI allows users to configure multiple devices at once and begin trending important system performance measurements within minutes. Users can be alerted when issues occur, and operators can identify root causes faster and resolve them sooner using powerful analytics and image view tools.

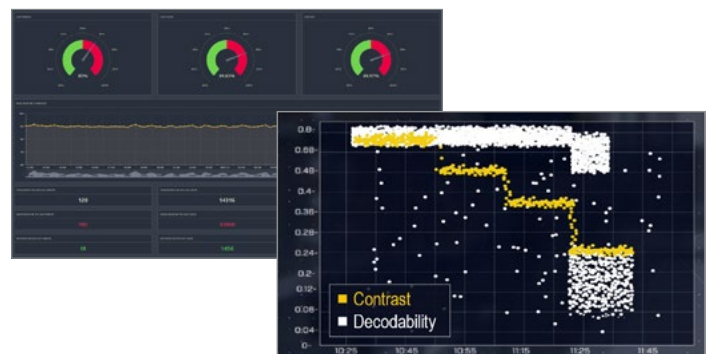

MACHINE VISION SYSTEMS



VISION SENSORS

In-Sight® 2000 vision sensors perform simple pass/fail applications that help ensure products and packaging manufactured on an automated production line are error-free and meet stringent quality standards.

2D VISION SYSTEMS

Cognex In-Sight 2D vision systems are unmatched in their ability to inspect, identify, and guide parts. These self-contained, industrial-grade vision systems combine a library of advanced vision tools with high-speed image acquisition and processing.



3D-A1000 VISION SYSTEMS

Cognex 3D-A1000 vision systems provide ease of use, simple setup, and high accuracy for dimensioning and item detection applications. They capture 3D and 2D images of objects and provide key operational information for logistics control systems.

COGNEX DEEP LEARNING SOFTWARE

Combining artificial intelligence (AI) with vision software, Cognex deep learning software solves location, assembly verification, inspection, classification and character reading applications that are too difficult, complex, or expensive for traditional machine vision systems and too fast for reliable, consistent results with human part inspection.



IMAGE-BASED BARCODE READERS

FIXED-MOUNT BARCODE READERS

Compact but powerful DataMan® barcode readers offer unmatched code reading performance with patented 1D and 2D code reading algorithms. The flexible options, easy setup, and quick deployment make them ideal for the most demanding industrial applications.



HANDHELD BARCODE READERS

Versatile DataMan barcode readers provide best-in-class performance for 1D, 2D, and DPM codes, where ruggedness and speed are critical to success. A range of field-changeable communication options ensure these readers are ready to meet your application requirements.



MOBILE TERMINALS

The MX series of vision-enabled mobile terminals leverage the latest iOS® and Android® smartphones in a rugged housing, tough enough to stand up to the most challenging environments—all while providing superior 1D, 2D, and DPM code read rates.



BUILD YOUR VISION

2D VISION SYSTEMS

Cognex machine vision systems are unmatched in their ability to inspect, identify and guide parts. They are easy to deploy and provide reliable, repeatable performance for common to complex tasks.

www.cognex.com/machine-vision



3D VISION SYSTEMS

Cognex laser profilers and area scan 3D vision systems provide ultimate ease of use, power and flexibility to achieve reliable and accurate measurement results for the most challenging 3D applications.

www.cognex.com/3D-vision-systems



VISION SOFTWARE

Cognex vision software provides industry leading vision technologies, from traditional machine vision to deep learning-based image analysis, to meet any development needs.

www.cognex.com/vision-software



BARCODE READERS

Cognex industrial barcode readers and mobile terminals with patented algorithms provide the highest read rates for 1D, 2D and DPM codes regardless of the barcode symbology, size, quality, printing method or surface.

www.cognex.com/barcodereaders



COGNEX

Companies around the world rely on Cognex vision and barcode reading solutions to optimize quality, drive down costs and control traceability.

Corporate Headquarters One Vision Drive Natick, MA 01760 USA

Regional Sales Offices

Americas

North America +1 844-999-2469
Brazil +55 11 4210 3919
Mexico +800 733 4116

Europe

Austria +49 721 958 8052
Belgium +32 289 370 75
France +33 1 7654 9318
Germany +49 721 958 8052

Hungary +36 800 80291
Ireland +44 121 29 65 163
Italy +39 02 3057 8196
Netherlands +31 207 941 398
Poland +48 717 121 086
Spain +34 93 299 28 14
Sweden +46 21 14 55 88
Switzerland +41 445 788 877
Turkey +90 216 900 1696
United Kingdom +44 121 29 65 163

Asia

China +86 21 6208 1133
India +9120 4014 7840
Japan +81 3 5977 5400
Korea +82 2 539 9047
Malaysia +6019 916 5532
Singapore +65 632 55 700
Taiwan +886 3 578 0060
Thailand +66 88 7978924
Vietnam +84 2444 583358

© Copyright 2022, Cognex Corporation.
All information in this document is subject to change without notice. All Rights Reserved.
Cognex, DataMan, In-Sight, 1DMax, Hotbars, 2DMax, and Powergrid are registered trademarks of Cognex Corporation. OCRMax is a trademark of Cognex Corporation. All other trademarks are property of their respective owners.
Lit. No. LOGSG-EN-05-2022

www.cognex.com